



Tank semi-trailers

Quality that pays off

HMK Bilcon is the Scandinavian dealer for **tank semi-trailers** from the German company Schrader Fahrzeugbau. The tank semi-trailers are constructed using the patented UNITAS 2000 cylinder profile with standard modules and components. There is a short delivery time for these trailers, and they are delivered in high quality at a competitive price.

Flexible Configuration

With Schrader's tank semi-trailers, it's possible to transport large quantities of fuel in one trip, as the trailers can carry up to 56 tons. The tank is constructed in aluminum, and it's possible to divide the tank into up to eight compartments. It can be built on a self-supporting aluminum chassis with two to four axles, and the cylinder profile provides the lowest possible center of gravity giving good traction conditions for the towing unit. Regarding fuel dispensing, there is the option to choose between bottom loading, free-fall delivery, or pump delivery through a hose reel with extraction from the right side.

BENEFITS

GOOD QUALITY AT A SHARP PRICE

OPTIMIZED SOLUTION

LOW WEIGHT

SHORT DELIVERY TIME

SERVICE AT HMK BILCON

Tank semi-trailers

Quality that pays off

Dimensions

Loading volume	56,000 kg
Length	13,990 mm
Length from king pin	12,000 mm
Width	2,550 mm
Height	3,400 mm
Wheel base from king-pin	8,750 mm
Height over ground of 5th wheel plate	1,200 mm unloaded
Max. load on king pin	18,000 kg
Max. load on axle	30,000 kg
Max. permitted weight	48,000 kg
Weight, empty	According to specifications

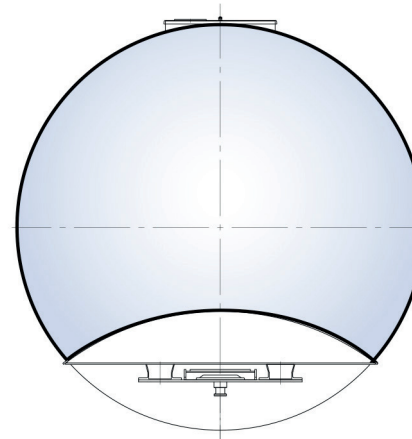

Schrader UNITAS 2000 profile